

## DMU11-21 OEM

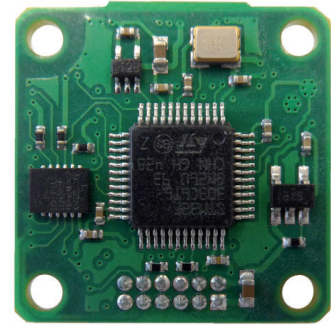
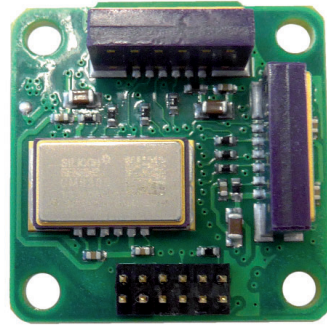
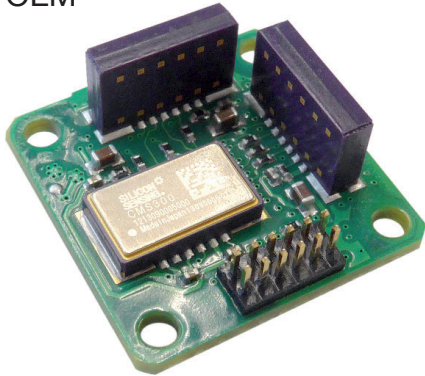

## Features

- High performance six degrees of freedom (6-DOF) low cost MEMS IMU
- 7 sensor outputs
  - Angular rate (x3)
  - Linear acceleration (x3)
  - Temperature
- Dynamic Range  $\pm 300^\circ/\text{s}$  and  $\pm 10\text{g}$
- Bias instability  $< 10^\circ/\text{hr}$  and  $0.05\text{mg}$
- Random Walk  $< 0.4^\circ/\sqrt{\text{hr}}$  and  $0.05\text{m/s}/\sqrt{\text{hr}}$
- Small (22 x 22.5 x 10.6mm)
- 3.2 to 5.25V Supply
- Wide operating temperature range  $-40^\circ\text{C}$  to  $+85^\circ\text{C}$
- RS-422 Interface
- RoHS and REACH compliant

## Applications

- Machine control
- Antenna and Platform Stabilisation
- Precision Agriculture
- Autonomous Vehicles and ROVs
- Attitude Measurement Systems
- Personal Navigation
- GPS Aiding

## 1 General Description

DMU11 is a low cost 6-DOF Precision MEMS Inertial Measurement Unit from Silicon Sensing Systems. It provides three axes of angular rate and linear acceleration, and temperature. The output message includes message counter, built-in test results, delta theta and delta velocity information. Data is output on an industry standard RS422 interface for ease of integration.

DMU11 is engineered using Silicon Sensing's own unique MEMS VSG5 ring gyroscope and capacitive accelerometer technologies to provide benchmark performance, size and affordability. It contains three 5th generation piezoelectric (PZT) gyroscopes and six accelerometers. Outputs from dual accelerometers per axis are averaged to improve precision and reduce uncorrelated noise.

DMU11 has been derived from DMU10 as a 'cut down' version of the IMU for higher volume applications where unit cost is paramount.

Full Evaluation Kit available (see Section 8 for details).

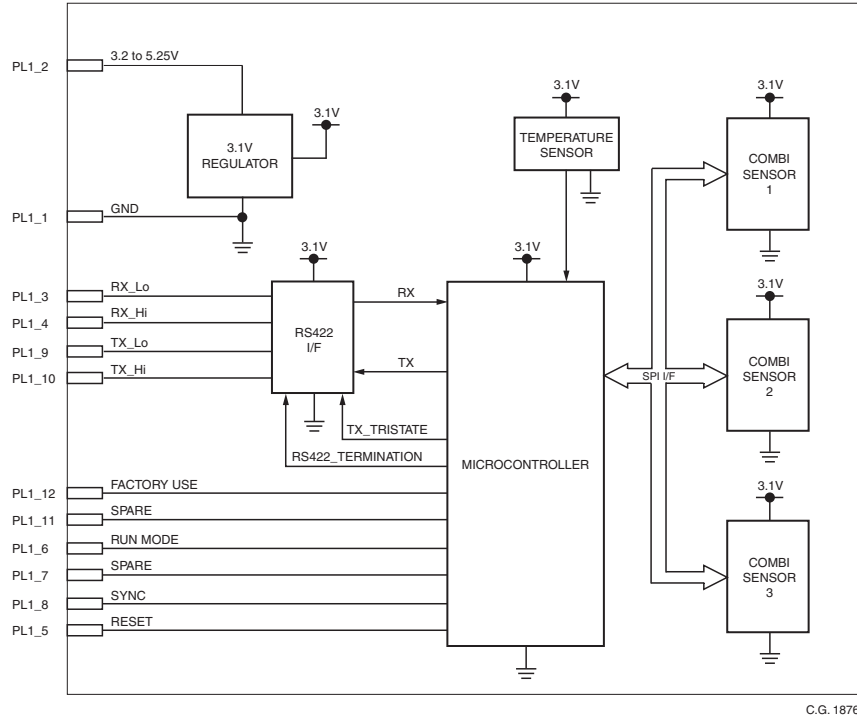

C.G. 18769

**Figure 1.1 DMU11 Functional Block Diagram**

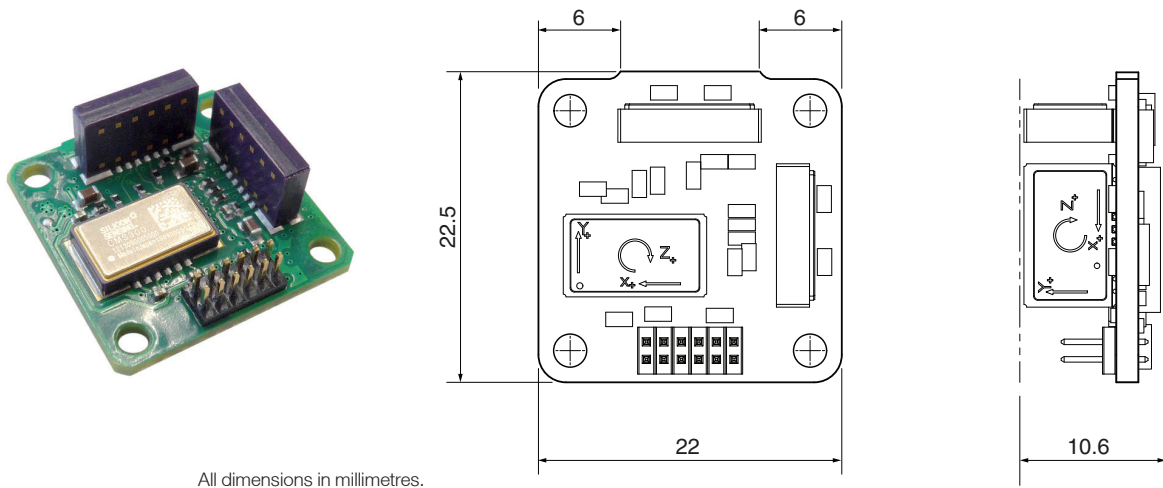

All dimensions in millimetres.

**Figure 1.2 DMU11 Overall Dimensions**



# DMU11 Technical Datasheet

Low Cost 6-DOF Precision  
MEMS Inertial Measurement Unit

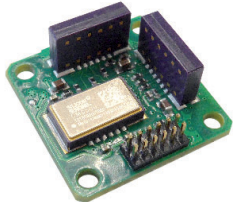

www.siliconsensing.com

## 2 Ordering Information

Item	Description	Overall Dimensions	Calibration	Part Number
		mm		
 <p>DMU11</p>	Bare PCB with four mounting holes, conformally coated.	22 x 22.5 x 10.6	Yes	DMU11-21-0100
 <p>DMU11 Evaluation Kit (EVK)</p>	Customer evaluation kit (EVK) comprising a DMU11-21-0100, RS422 to USB Connector, USB Driver and Data Logging Software, Cables and Connectors, Instruction Manual. (see section 8.1)	Not Applicable	Yes	DMU11-21-0500
 <p>DMU11 Optional Mating Connector</p>	Optional mating socket connector and interconnected flying lead. (see section 7.2)	450	N/A	630486-0946

## 3 Performance

Parameter	Minimum	Typical	Maximum	Notes
<b>Angular Rate (Roll, Pitch, Yaw)</b>				
Dynamic Range (°/s)	< -300	–	> +300	Clamped at ±305°/s during over-range
Scale Factor Error (%)	-0.25	±0.10	+0.25	–
Scale Factor Non-Linearity Error (%)	-0.067	±0.033	+0.067	–
Bias (°/s)	-0.50	±0.25	+0.50	Over operating temperature range
Bias drift with time (°/s)	-0.05	±0.025	+0.05	For the first 15 minutes of operation after power on at constant temperature
Bias Instability (°/hr)	–	< 10.00	–	As measured using the Allan Variance method
Angle Random Walk (°/√hr)	–	< 0.40	–	
Orthogonality (°)	-0.2	±0.1	+0.2	Error between sense axes
Gyro Bandwidth (Hz)	69	77 ±2	85	-3dB point
Noise (°/s rms)	–	0.10	0.15	Wide band noise at 100Hz
Noise Under Vibration (°/s rms / g)	-0.006	±0.003	+0.006	3.3g rms stimulus 20Hz to 2,000Hz

### 3 Performance Continued

Parameter	Minimum	Typical	Maximum	Notes
<b>Linear Acceleration (X, Y, Z)</b>				
Dynamic Range (g)	< -10	–	> +10	Clamped at ±10.01g during over-range
Scale Factor Error (%)	-0.25	±0.10	+0.25	–
Scale Factor Non-Linearity Error (%)	-1.00	±0.50	+1.00	Maximum error from best straight line over ±10g
Bias (mg)	-6.0	±3.0	+6.0	Over operating temperature range
Bias drift with time (mg)	-2.00	±1.00	+2.00	For the first 15 minutes of operation after power on at constant temperature
Bias Instability (mg)	–	< 0.05	–	As measured using the Allan Variance method.
Random Walk (m/s/√hr)	–	< 0.05	–	
Orthogonality (°)	-0.2	–	+0.2	Error between sense axes
Acc Bandwidth (Hz)	63	69 ±3	75	-3dB point
Noise (mg rms)	–	1.00	1.50	Wide band noise at 100Hz
<b>Temperature Output</b>				
Range (°C)	< -45	–	> 100	Exceeds operational temperature range
Accuracy (°C)	–	±3	–	In the operational temperature range

## 4 Environment, Power and Physical

Parameter	Minimum	Typical	Maximum	Notes
<b>Environment</b>				
Operating Temperature Range (°C)	-40	-	+85	Full specification
Storage Temperature Range (°C)	-40	-	+100	-
G-Sensitivity (%/g)	-0.01	±0.006	+0.01	-
Operational Shock (g)	-	-	95	6ms, half sinewave
Non-Operational Shock (g)	-	-	500	1.0ms, half sinewave
Operational Random Vibration (g rms)	-	-	3.3	20Hz to 2KHz
Non-Operational Random Vibration (g rms)	-	-	10	20Hz to 2KHz
Humidity (% rh)	-	-	85	Non-condensing
<b>Interface</b>				
Communication Protocol (Standard)	-	RS-422	-	Full duplex communication
Data Rate (Hz)	-	200 (Default)	-	-
Baud Rate (BPS)	-	460800 (Default)	-	-
Latency (ms)	-	2.5	-	-
Startup Time (s)	-	< 0.5	-	-
Current (mA)	-	85	95	With 120 Ω RS422 termination resistor
Voltage (V)	+3.2	+5	+5.25	-
<b>Physical</b>				
Size (mm)	-	22 x 22 x 10.6	-	-
Mass (grams)	-	4	-	-

## 5 Typical Performance Characteristics

This section shows the typical performance of DMU11

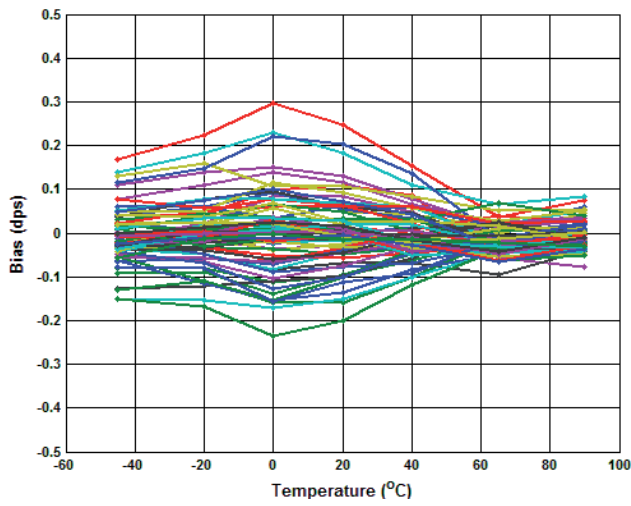

Figure 5.1 Gyroscope Bias

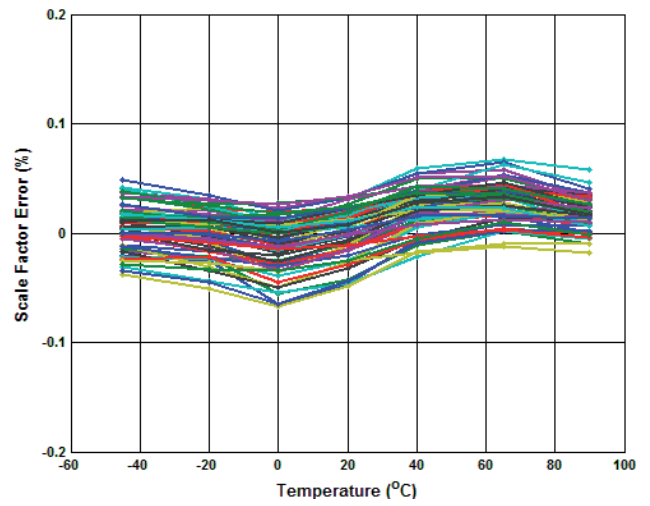

Figure 5.2 Gyroscope Scale Factor Error

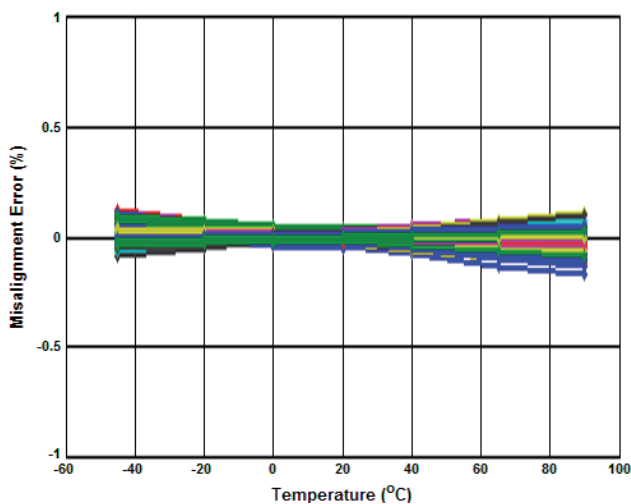

Figure 5.3 Gyroscope Cross Axis Sensitivity

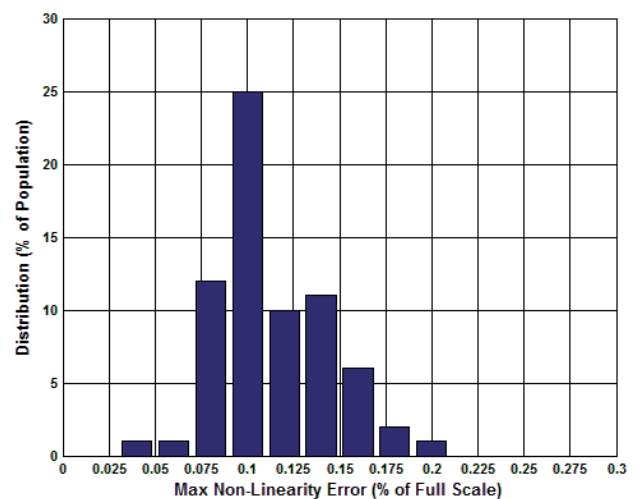

Figure 5.4 Gyroscope Non-Linearity Distribution

## Typical Performance Characteristics

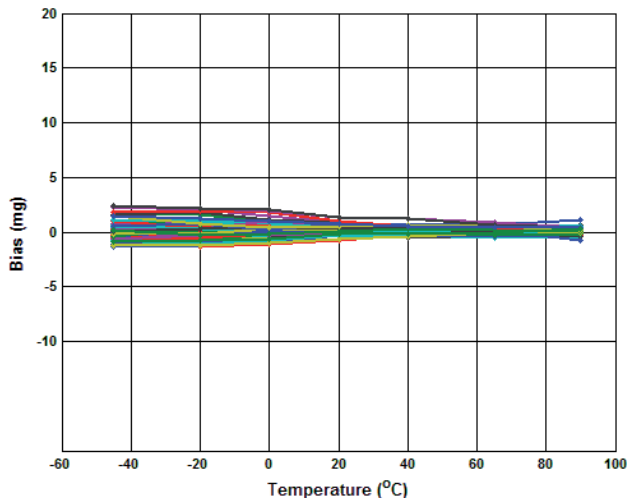

Figure 5.5 Accelerometer Bias

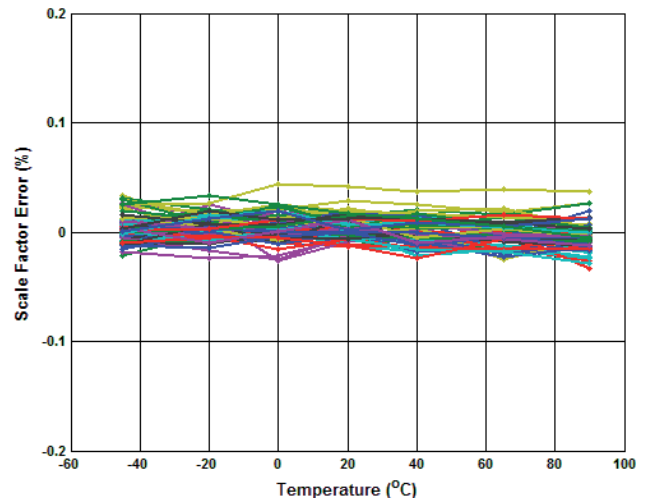

Figure 5.6 Accelerometer Scale Factor Error

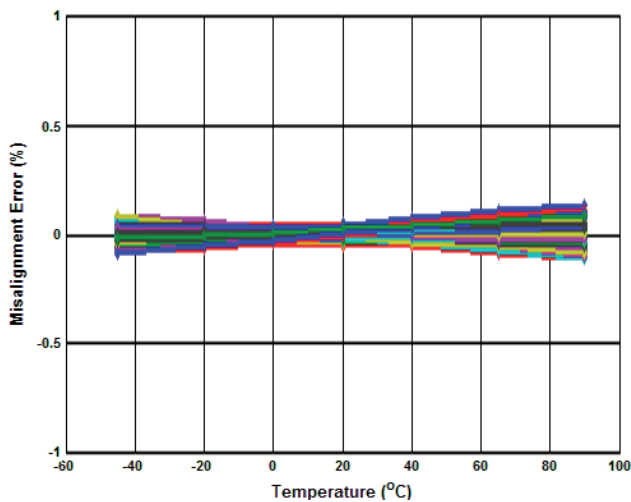

Figure 5.7 Accelerometer Cross Axis Sensitivity

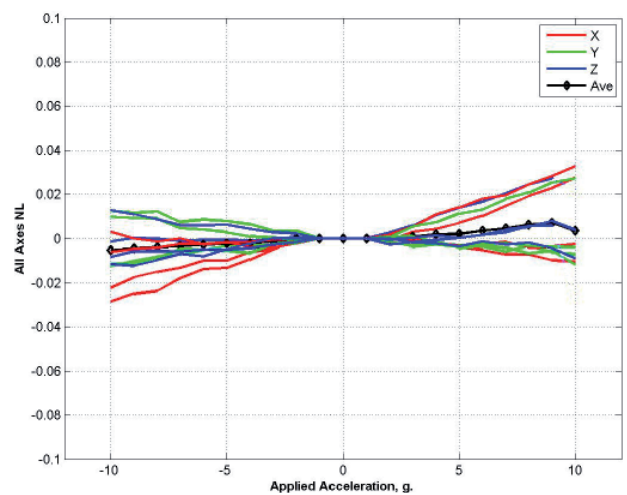

Figure 5.8 Accelerometer Non-Linearity Error



## Typical Performance Characteristics

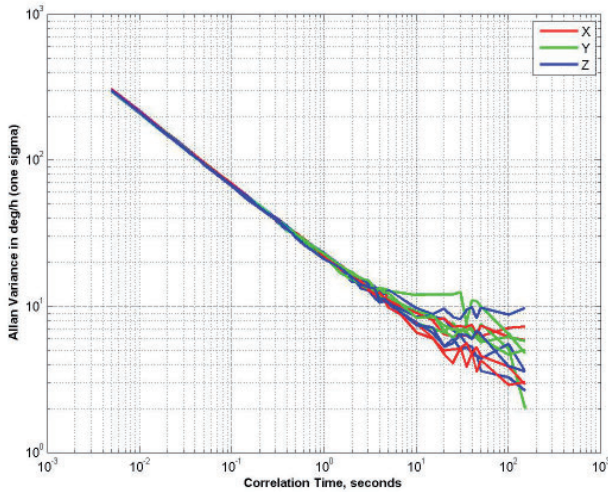

Figure 5.9 Gyroscope Allan Variance

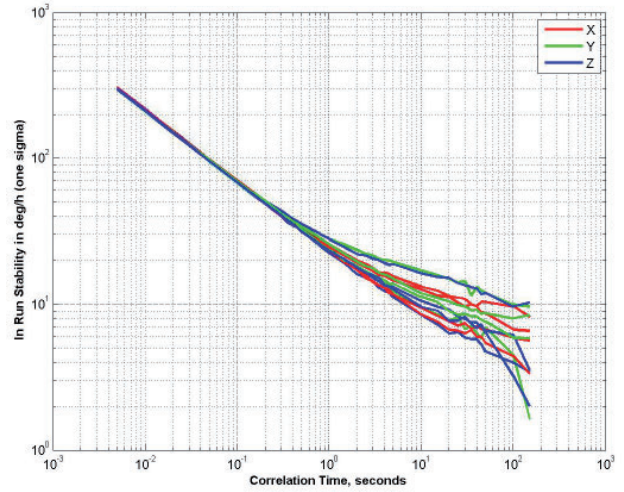

Figure 5.10 Gyroscope Stability

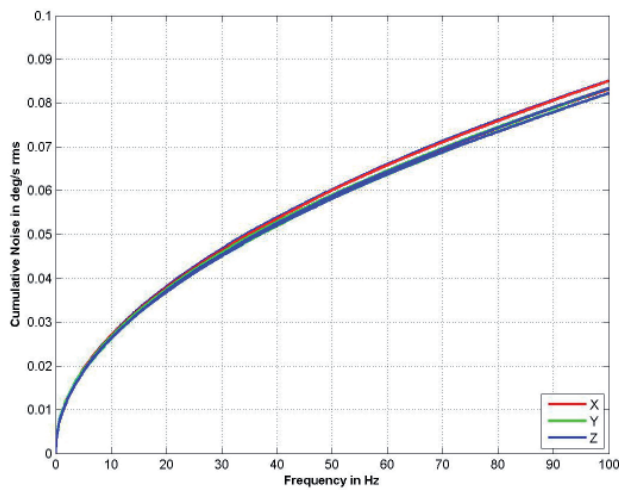

Figure 5.11 Gyroscope Cumulative Noise

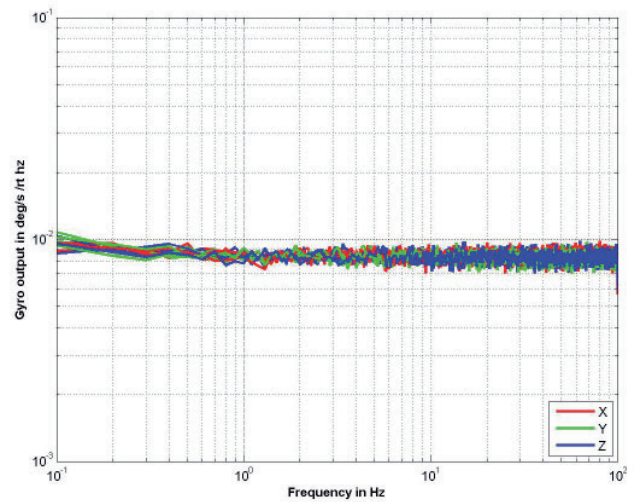
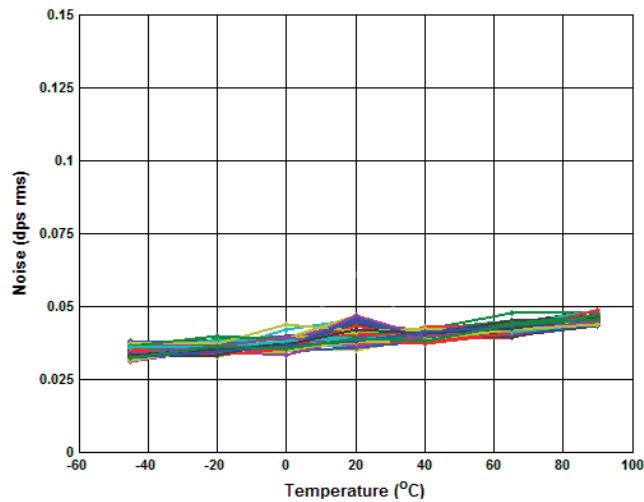
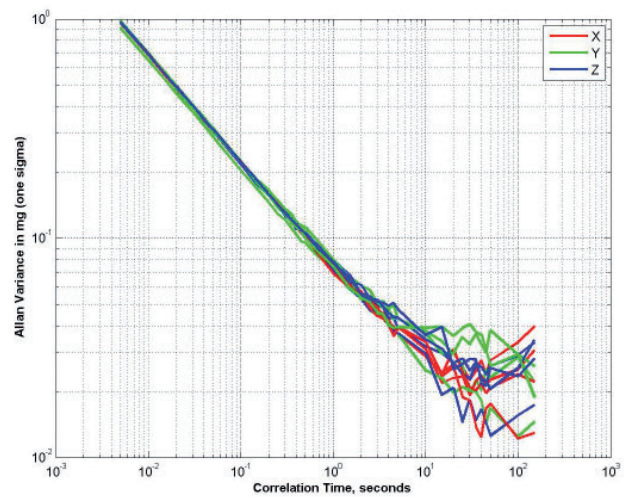

Figure 5.12 Gyroscope Spectral Noise

## Typical Performance Characteristics



**Figure 5.13 Gyroscope Noise over Temperature**



**Figure 5.14 Accelerometer Allan Variance**

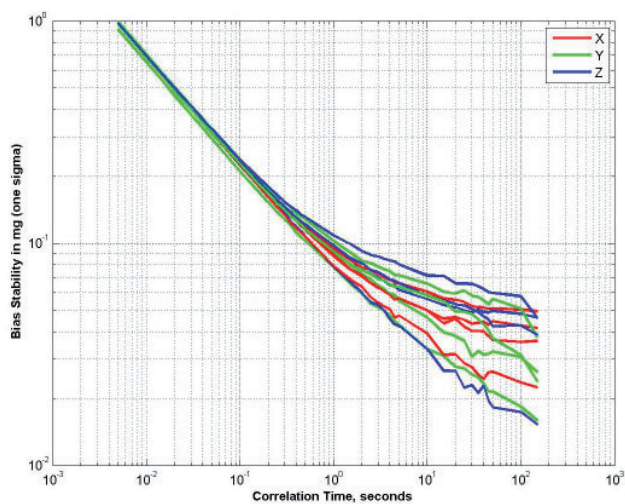

**Figure 5.15 Accelerometer Stability**

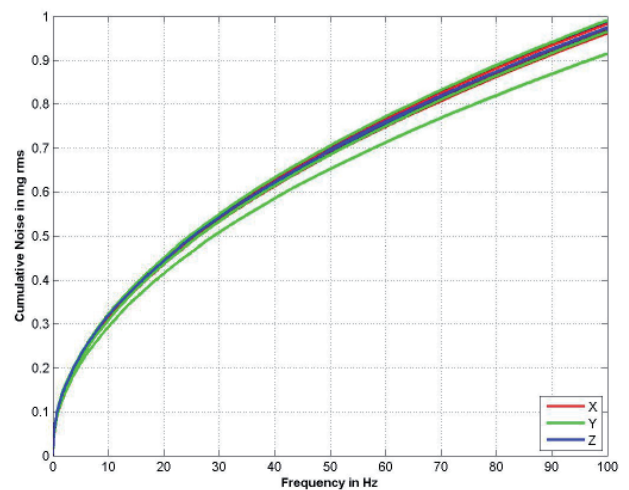

**Figure 5.16 Accelerometer Cumulative Noise**

## Typical Performance Characteristics

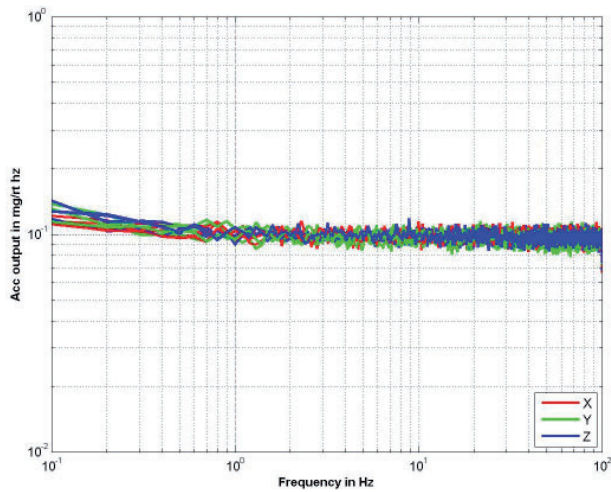

Figure 5.17 Accelerometer Spectral Noise

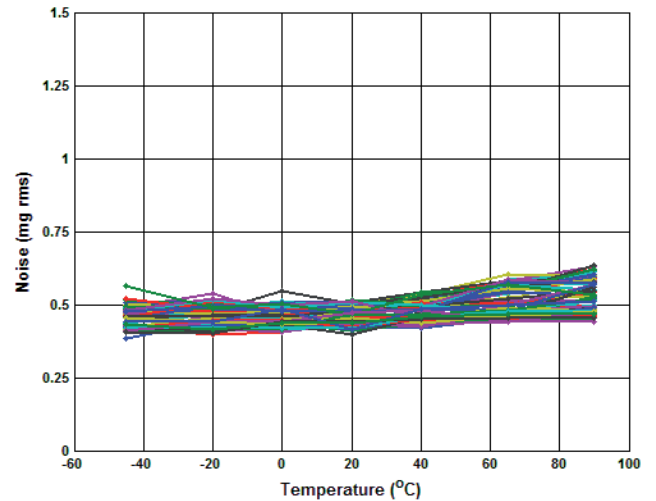

Figure 5.18 Accelerometer Noise over Temperature

## 6 Glossary of Terms

ADC	Analogue to Digital Converter
ARW	Angle Random Walk
AWG	American Wire Gauge
BPS	Bits Per Second (or Baud Rate)
BW	Bandwidth
C	Celsius or Centigrade
DAC	Digital to Analogue Converter
DPH	Degrees Per Hour
DPS	Degrees Per Second
DRIE	Deep Reactive Ion Etch
EMC	Electro-Magnetic Compatibility
ESD	Electro-Static Damage
EVK	Evaluation Kit
F	Farads
h	Hour
HBM	Human Body Model
Hz	Hertz, Cycles Per Second
K	Kilo
MDS	Material Datasheet
MEMS	Micro-Electro Mechanical Systems
mV	Milli-Volts
NEC	Not Electrically Connected
NL	Scale Factor Non-Linearity
OEM	Original Equipment Manufacturer
OT	Over Temperature
PD	Primary Drive
PP	Primary Pick-Off
RC	Resistor and Capacitor filter
RoSH	Restriction of Hazardous Substances
REACH	Registration, Evaluation, Authorisation and Restriction of Chemicals
RT	Room Temperature
s	Seconds
SF	Scale Factor
SMT	Surface Mount Technology
SOG	Silicon On Glass
SD	Secondary Drive
SP	Secondary Pick-Off
T.B.A.	To Be Advised

T.B.D. To Be Determined

V Volts

## 7 Interface

Physical and electrical inter-connect and RS422 message information.

### 7.1 Electrical Interface

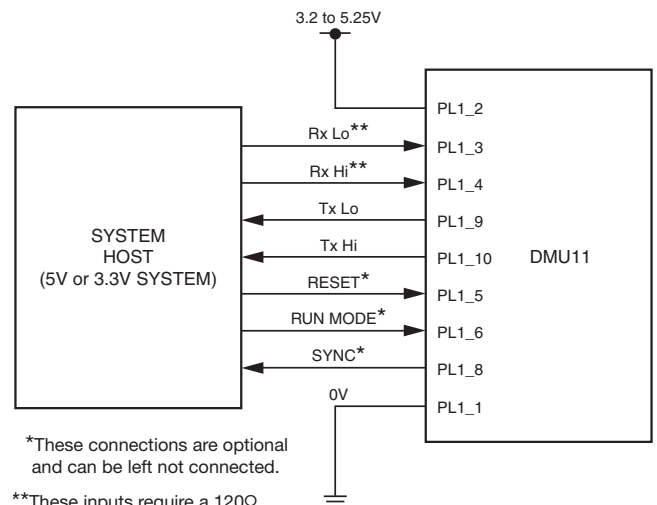

\*These connections are optional and can be left not connected.

\*\*These inputs require a 120Ω termination resistor.

C.G.18770

**Figure 7.1 Required Connections for RS422 Communications with DMU11**

### 7.2 Physical Interface

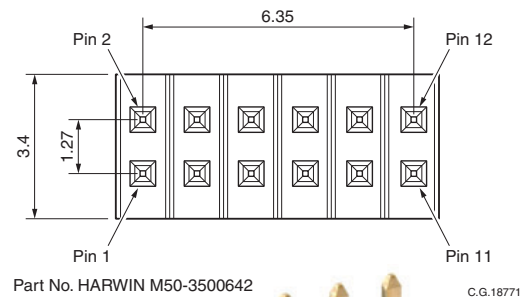

Part No. HARWIN M50-3500642

C.G.18771

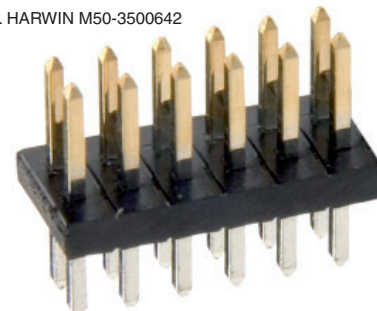

**Figure 7.2 Male Connector DMU11**

Figure 10.1 shows the orientation of the connector on the DMU11.





**Figure 7.3 Optional Mating Connector DMU11**

## 7.3 Connector Specification

The physical electrical interface for the DMU11 is made via the 'Archer M50' series of connectors produced by Harwin. The Harwin part number for the DMU11 board mounted connector is M50-350064: 1.27mm Pitch, 3mm Pin Height, DIL Vertical PC Tail Pin Header. Please visit the Harwin website for the connector drawing and specification:

[www.harwin.com/products/M50-350064/](http://www.harwin.com/products/M50-350064/).

Mating Connector and Cable: Silicon Sensing can supply an optional mating connector with flying leads for the DMU11 - see Figure 7.3. This comprises a Harwin Archer M50 DIL Vertical Socket (Harwin Part Number M50-3000645) mounted to a small PCBA for strain relief, fed by 450mm long unterminated flying leads - Ordering Part Number: 630486-0946

## 7.4 Pin Information

Pin	Label	Signal	In/Out
1	GND	Ground connected of the DMU11	I
2	+5V	Input voltage to the DMU11. Can be between 3.2V and 5.25V	I
3	Rx Lo*	The negative receive connection required for the RS422 communication	I
4	Rx Hi*	The positive receive connection required for the RS422 communication	I
5	Reset	Microprocessor reset. Pin is pulled low to reset the device. Suggested implementation using TTL logic	I
6	Run Mode	Device Enable/Disable. Pin is pulled high or not connected to enable the device. Pin is pulled low to disable the device. Suggested implementation using TTL logic	I
7	Spare	Spare for future use and should not be interfaced with	N/A
8	Sync	Output signal that can be used by an external system to synchronise with DMU11	O
9	Tx Lo	The negative transmit connection required for the RS422 communication	O
10	TX Hi	The positive transmit connection required for the RS422 Communication	O
11	Spare	Not electrically connected	N/A
12	Factory Use	Used by SSSL for programming purposes and should not be interfaced with	N/A

\* 120Ω termination resistor required externally.

**Table 7.1 Pin Information**

## 7.5 Communications with DMU11

The Run Mode pin on the connector is used to control the output from the DMU11. The “Free Run” or “Enabled” mode is active when the Pin is floating (not connected), and the output will be enabled.

The DMU11 output is disabled when the “Run Mode” Pin is pulled low.

## 7.6 Operational Message Output

The Output Message is output on a RS422 Serial output at 460,800 baud using a non-return to zero protocol. Each byte contains a start bit (logic 0), 8 data bits and 2 stop bits (logic 1). Data is output in big endian format by default.

Data is output at a rate of 200 messages per second.

Each message contains 34 words (68 bytes) as described in Table 7.2. The message is transmitted if the “Run Mode” Pin is High (NC).

If the “Run Mode” Pin changes to a Low (Disable output), while the message is being transmitted, the message is completed before the output is disabled.

## 7.7 Sensor Sampling and Synchronisation

The Inertial Sensors within DMU11 are all sampled at 1,000Hz. The ‘Sync Pulse’ on the connector is set HIGH at the start of the sampling and returned to LOW when the last Inertial Sensor is sampled. Pulses are therefore seen on the connector at 1,000Hz.

The Inertial Sensor measurements are then filtered with a 2nd order low pass filter, also running at 1000Hz. The factory default setting for this filter has a corner frequency of > 85Hz.

The internal sequence for DMU11 is:

- Cycle 1: Sample Sensors, 2nd order Filter
- Cycle 2: Sample Sensors, 2nd order Filter, Calculate Sensor Compensation
- Cycle 3: Sample Sensors, 2nd order Filter, Apply Sensor Compensation
- Cycle 4: Sample Sensors, 2nd order Filter
- Cycle 5: Sample Sensors, 2nd order Filter, Transmit Message

The message is transmitted after the ‘Sync Pulse’ associated with Cycle 5 has returned LOW. The inertial data included in the message is generated when the ‘Sync Pulse’ associated with Cycle 3 was HIGH. This enables the external equipment to synchronise with the time when the Inertial Data was valid.

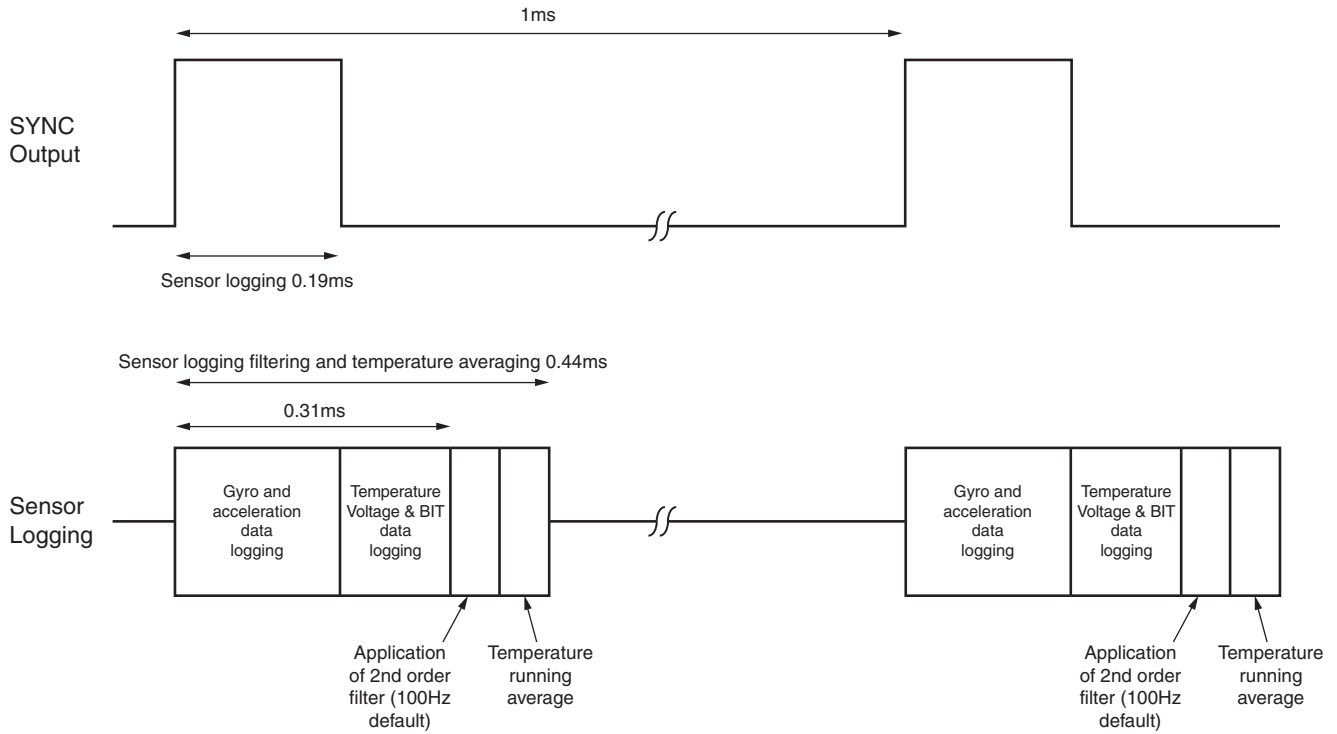

C.G. 18738

**Figure 7.4 Relationship between SYNC and Sensor Logging**

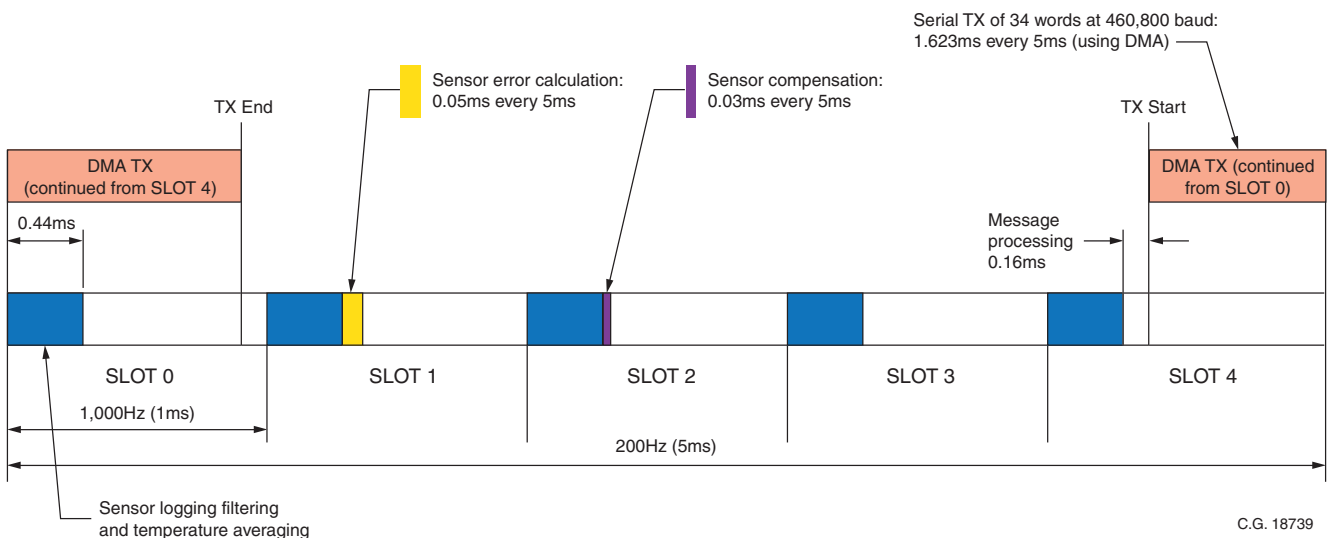

C.G. 18739

**Figure 7.5 Relationship between Sensor Logging, Compensation and Transmitted Output**

## 7.8 Operational Message Definitions

The data output message has the content and sequence as shown in the table below:

Item	Word	Data Item	Value / Unit
0	0	Header	16 Bit, 0x55AA
1	1	Message Count	16 Bit, 0 to 65535 decimal
2	2-3	Axis X Rate	32 Bit Single Precision FP, (°/s)
3	4-5	Axis X Acceleration	32 Bit Single Precision FP, (g)
4	6-7	Axis Y Rate	32 Bit Single Precision FP, (°/s)
5	8-9	Axis Y Acceleration	32 Bit Single Precision FP, (g)
6	10-11	Axis Z Rate	32 Bit Single Precision FP, (°/s)
7	12-13	Axis Z Acceleration	32 Bit Single Precision FP, (g)
8	14-15	Reserved	Reserved
9	16-17	Average IMU Temperature	32 Bit Single Precision FP, (°C)
10	18-19	Axis X Delta Theta	32 Bit Single Precision FP, (°)
11	20-21	Axis X Delta Vel	32 Bit Single Precision FP, (m/s)
12	22-23	Axis Y Delta Theta	32 Bit Single Precision FP, (°)
13	24-25	Axis Y Delta Vel	32 Bit Single Precision FP, (m/s)
14	26-27	Axis Z Delta Theta	32 Bit Single Precision FP, (°)
15	28-29	Aux Z Delta Vel	32 Bit Single Precision FP, (m/s)
16	30	System Startup BIT Flags	16 Bit decimal value
17	31	System Operation BIT Flags	16 Bit decimal value
18	32	Reserved	Reserved
19	33	Checksum	16 Bit 2's Complement of the 16 Bit Sum of the Previous 0-18 data items

**Table 7.2 Operational Message Data Output Definitions**

## 7.9 System BIT Flags

### 7.9.1 System Startup BIT Flags

These flags indicate errors detected during DMU11 Initialisation. Once set, these flags will not be cleared for the whole of the power cycle.

BIT No.	System Startup BIT Flags
D00	<b>Code_Checksum_Fail</b> Set if the DMU11 code checksum does not match. If this flag is set, correct operation of the DMU11 cannot be guaranteed.
D01	<b>NVM_Coefficient_Checksum_Fail</b> Set if the DMU11 NVM coefficient checksum does not match. If this flag is set, correct operation of the DMU11 cannot be guaranteed.
D02	<b>CMS300_Startup_Error</b> This flag will be set if there were any CMS300 Startup Flags set in any of the three 32 BIT CMS300 BIT flag arrays. The output items affected by this failure will be marked in the Item Error Indication table.
D03	<b>Internal_Processor_Error</b> Set if there was an error accessing hardware internal to the microprocessor.
D04	<b>Invalid_NVM_Coefficient</b> Set if an NVM coefficient value is invalid. If this affects an operational output item, the corresponding item will be marked in the Item Error Indication table and this should help to identify which coefficient is invalid.
D05	Spare
D06	Spare
D07	Spare
D08	Spare
D09	Spare
D010	Spare
D011	Spare
D012	Spare
D013	Spare
D014	Spare
D015	Spare

**Table 7.3 System Startup BIT Flags**



## 7.9.2 System Operation BIT Flags

These flags indicate errors detected during DMU11 operation. These flags are set per DMU11 output message and so may not appear in every returned message (because the fault may clear or be intermittent).

BIT No.	System Operation BIT Flags
D00	<b>Voltage_Regulator_Range_Error</b> Regulator Voltage BIT Function.
D01	<b>Scheduler_Slot_Period_Extended</b> This flag will be set if the DMU11 software scheduler could not complete its allocated tasks within the required slot time. If this happens, the DMU11 will widen its scheduler slot time. This will normally be caused by a hardware fault that caused a timeout. When this flag is set, the DMU11 will output data at a decreased rate.
D02	<b>Output_Message_Missed</b> This flag will be set if the previous output message was missed. This will occur if the DMU11 was unable to output a serial port message because the previous message was still being sent. This will normally be caused by incompatible Message or Baud Rate selection.
D03	<b>Internal_Processor_Error</b> This flag will be set if the software timed out while accessing hardware internal to the microprocessor (A/D, SPI). The output items affected by this failure will be marked in the Item Error Indication table.
D04	<b>CMS300_Operation_Error</b> This flag will be set if there are any CMS300 Operation Flags set in any of the three 32 BIT CMS300 BIT flag arrays. The output items affected by this failure will be marked in the Error Indication table.
D05	<b>Output_Value_Out_Of_Range</b> Set when an output value has been clamped because it is out of range. The output items affected by this failure will be marked in the Error Indication table. Max Rate = $\pm 305^\circ/\text{s}$ Max Acceleration = $\pm 10.01\text{g}$
D06	<b>Plausibility_Error</b> Set when the system has determined that a sampled sensor value is implausible. The output items affected by this failure will be marked in the Error Indication table.  This currently only applies to accelerometer sensors which have corresponding sensors in the same sense axis.
D07	Spare
D08	Spare
D09	Spare
D010	Spare

BIT No.	System Operation BIT Flags
D011	Spare
D012	Spare
D013	Spare
D014	Spare
D015	Spare

Table 7.4 System Operation BIT Flags

## 7.9.3 System Error Indication BIT Flags

These flags indicate which message items have faults associated with them (refer to Table 7.2 for “Message Items”).

BIT No.	System Error Indication BIT Flags
D00	Message Item 2 Error (X axis Rate for standard message format).
D01	Message Item 3 Error (X axis acceleration for standard message format).
D02	Message Item 4 Error (Y axis Rate for standard message format).
D03	Message Item 5 Error (Y axis acceleration for standard message format).
D04	Message Item 6 Error (Z axis Rate for standard message format).
D05	Message Item 7 Error (Z axis acceleration for standard message format).
D06	Message Item 8 Error (Auxillary input for standard message format).
D07	Message Item 9 Error (Temperature for standard message format).
D08	Message Item 10 Error (X delta theta for standard message format).
D09	Message Item 11 Error (X delta velocity for standard message format).
D010	Message Item 12 Error (Y delta theta for standard message format).
D011	Message Item 13 Error (Y delta velocity for standard message format).
D012	Message Item 14 Error (Z delta theta for standard message format).
D013	Message Item 15 Error (Z delta velocity for standard message format).
D014	Message Item 16 Error.
D015	Message Item 17 Error.

Table 7.5 System Error Indication BIT Flags

## 8 Design Tools and Resources Available

Item	Description of Resource	Part Number	Order/Download
	<p><b>DMU11 Brochure:</b> A one page sales brochure describing the key features of the DMU11 Inertial Measurement Unit.</p>	DMU11-00-0100-131	<p>Download (www.siliconsensing.com)</p>
	<p><b>DMU11 Datasheet:</b> Full technical information on all DMU11 Dynamic Measurement Unit part number options. Specification and other essential information for assembling and interfacing to DMU11 Inertial Measurement Unit, and getting the most out of it.</p>	DMU11-00-0100-132	<p>Download (www.siliconsensing.com)</p>
	<p><b>DMU11 Evaluation Kit:</b> DMU11 delivered with an RS422 to USB interface, plug-and-play real time display and logging software and two interface cabling solutions DMU11-21-0100 unit included.</p>	DMU11-21-0500	<p>Order (www.siliconsensing.com)</p>
	<p><b>DMU11 Presentation:</b> A useful presentation describing the features, construction, principles of operation and applications for the DMU11 Inertial Measurement Unit.</p>	—	<p>Download (www.siliconsensing.com)</p>
	<p><b>Solid Model CAD files for DMU11 Inertial Measurement Unit:</b> Available in .STP and .IGS file format.</p>	DMU11-21-0100-408	<p>Download (www.siliconsensing.com)</p>
	<p><b>Interface:</b> Off-the-peg pseudo code and a simple flowchart with message handling instructions for use as a customer aid to developing their own interface directly to a DMU11 Inertial Measurement Unit via the RS422 interface.</p>	—	<p>Download (www.siliconsensing.com)</p>
	<p><b>DMU11 Mating Connector:</b> Optional mating socket connector and unterminated flying lead.</p>	630486-0946	<p>Order (www.siliconsensing.com)</p>

## 8.1 DMU11 Evaluation Kit (EVK)

The DMU11 Evaluation Kit enables the output data from the DMU11 to be viewed and logged for testing and evaluation purposes.



Figure 8.1 DMU11 Evaluation Kit (EVK)

### 8.1.1 DMU11 Evaluation Kit Contents

The DMU11 Evaluation Kit (part number DMU11-21-0500) contains the following:

DMU11 IMU (part number DMU11-21-0100).

- MEV RS485i to USB converter.
- Interface cables.
- User manual.

### 8.1.2 System Requirements

The DMU11 Evaluation Kit requires a PC with a USB port. The requirements for the PC are as follows:

- Microsoft® Windows® Vista®, Windows 7 or Windows 8 Operating Systems.  
The software has not been tested on any other Operating System and therefore correct functionality cannot be guaranteed.
- Minimum of 500Mb of RAM.
- 500Mb of free hard drive space plus space for logged data (typical data rate ≈ 50kbit/s).
- High power or self-powered USB 2.0 Port.

## 9 Part Identification

For practical reasons the DMU11 PCB Assembly is not uniquely marked, however each DMU11 can be uniquely identified by the 12 digit part identification code located on the bottom right-hand corner of the CMS300 Combi Sensor [Yaw Rate Sensor - (Y)] - See Figure 9.1.

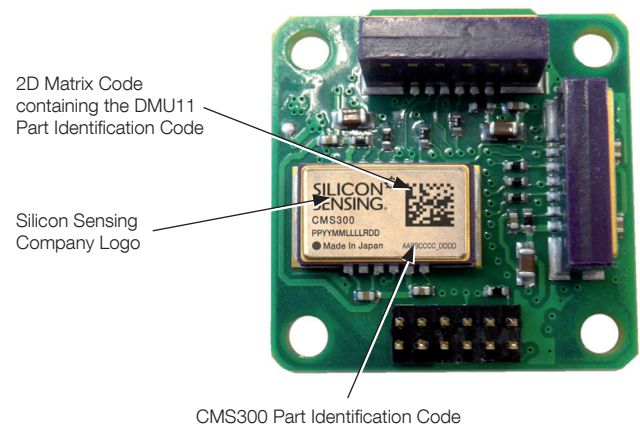

Figure 9.1 Part Identification

The part identification code numeric range is specified in Table 9.1.

Item	Item	Range
Part Identification Code	YYMMCCCCDDDD	YY = 00-99 MM = 01-12 CCCC = 0000-9999 DDDD = 0001-9999

Table 9.1 Part Identification Code

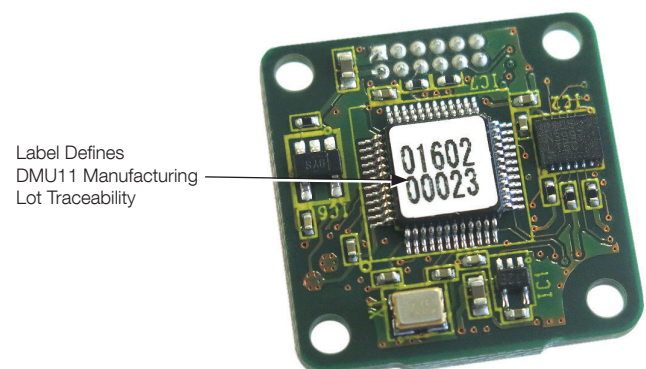

Figure 9.2 Lot Traceability

## 10 Installation Details

Figure 10.1 shows the installation drawing for DMU11.

The PCBA is intended to be secured to the host platform using four mounting holes provided. The holes are clearance holes for use with M2.0 machine screws. To provide sufficient clearance it is recommended that spacers are used, these must not extend beyond 'Keep In' shaded areas indicated on the installation drawing.

The DMU11 mounting screw torque settings will be dependent on the host application; it will for example vary depending on the specification of the screw, the material of the host structure and whether a locking compound is used. When securing a DMU11 unit to the host system using steel M2 screws and a thread

locking compound the suggested torque setting is 0.1Nm for securing to an aluminium host structure. This information is provided for guidance purposes only, the actual torque settings are the responsibility of the host system designer.

During manufacture of DMU11 Silicon Sensing performs internal sensor alignment calibration between the axes of the three combi sensors. This alignment calibration is performed with reference to the Yaw Plane (Z-Axis) via the mounting holes. For best results it is recommended that during installation the DMU11 is aligned to the host platform by the customer by electronically trimming out any difference between DMU11 axes and system level axes.

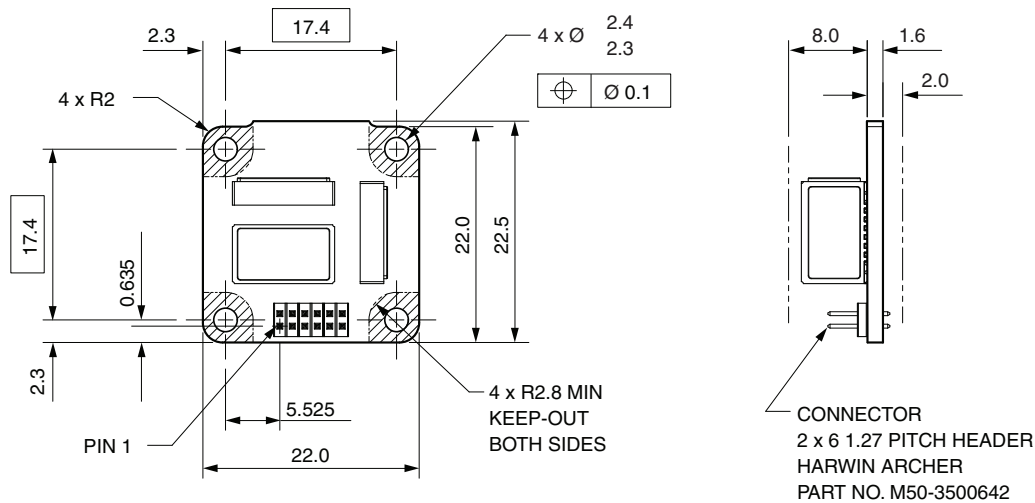

All dimensions in millimetres.

C.G. 18772

Figure 10.1 DMU11 Installation Drawing

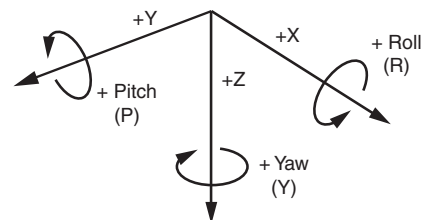
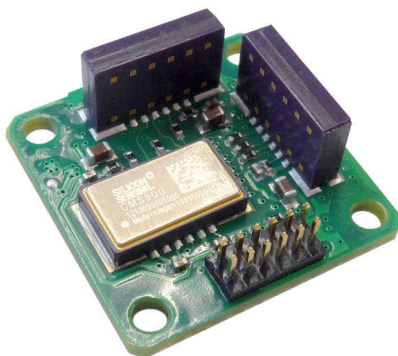

Figure 10.2 Axis Definitions

## 11 DMU11 MEMS Sensor Internal Construction and Theory of Operation

### Construction

The DMU11 uses three MEMS rate and acceleration Combi-Sensors providing three gyroscopes and six accelerometers.

Each Combi-Sensor comprises six main components; Silicon MEMS Single-Axis Angular Rate Sensor, Silicon On Glass (SOG) Dual-Axis MEMS Accelerometer, Silicon Pedestal, ASIC Package Base and Lid. The MEMS Sensors, ASIC and Pedestal are housed in a hermetically sealed package cavity with a nitrogen back-filled partial vacuum, this has particular advantages over sensors supplied in plastic packages which have Moisture Sensitivity Level limitations.

An exploded drawing of a Combi-Sensor showing the main components is given in Figure 11.1 below.

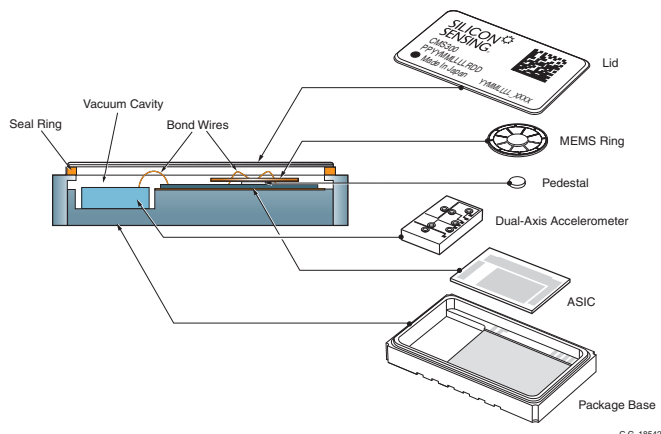

**Figure 11.1 Combi-Sensor Main Components**

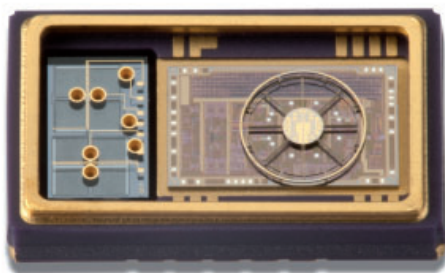

**Figure 11.2 Combi-Sensor (Lid Removed)**

### Silicon MEMS Ring Sensor (Gyro)

The 3mm diameter by 65µm thick silicon MEMS ring is fabricated by Silicon Sensing using a DRIE (Deep Reactive Ion Etch) bulk silicon process. The annular ring is supported in free-space by eight pairs of 'dog-leg' shaped symmetrical spokes which radiate from a central 1mm diameter solid hub.

The bulk silicon etch process and unique patented ring design enable close tolerance geometrical properties for precise balance and thermal stability and, unlike other MEMS gyros, there are no small gaps to create problems of interference and stiction. These features contribute significantly to DMU11's bias and scale factor stability over temperature, and vibration and shock immunity. Another advantage of the design is its inherent immunity to acceleration induced rate error, or 'g-sensitivity'.

Piezoelectric (strain) thin film actuators/transducers are attached to the upper surface of the silicon ring perimeter and are electrically connected to bond pads on the ring hub via tracks on the spokes. These actuate or 'drive' the ring into its  $\cos 2\theta$  mode of vibration at a frequency of 22kHz or detect radial motion of the ring perimeter either caused by the primary drive actuator or by the coriolis force effect when the gyro is rotating about its sensing axis. There is a single pair of primary drive actuators and a single pair of primary pick-off transducers, and two pairs of secondary pick-off transducers.

The combination of transducer technology and eight secondary pick-off transducers improves the DMU11's signal-to-noise ratio, the benefit of which is a very low-noise device with excellent bias over temperature performance.

### Silicon MEMS Dual-Axis Accelerometer

The Combi-Sensor dual-axis open loop accelerometer is a one-piece resonating silicon MEMS structure anodically bonded to top and bottom glass substrates to form a hermetically sealed Silicon on Glass (SOG) wafer sub-assembly. The same DRIE bulk silicon process as used to create the gyro in is used to create two orthogonal finger-like spring/seismic proof mass structures, each measuring 1.8mm square, and with a resonant frequency of 2.9kHz. Figure 11.3 shows a schematic cross section through the SOG wafer.



Capacitive drive and pick-off signals are transmitted by wire bond interconnections, in through-glass vias, between the metallised transducer plates on the MEMS proof mass and the ASIC.

Multiple inter-digitated fingers create increased capacitance thus enabling a high signal-to-noise ratio. The fingers are tapered to increase the resonant frequency and also have a high aspect ratio to provide highly stable performance. The differential gaps between the static electrode fingers and those of the proof mass provide an air squeeze film with near-critical damping.

Control of the accelerometer is handled by the ASIC.

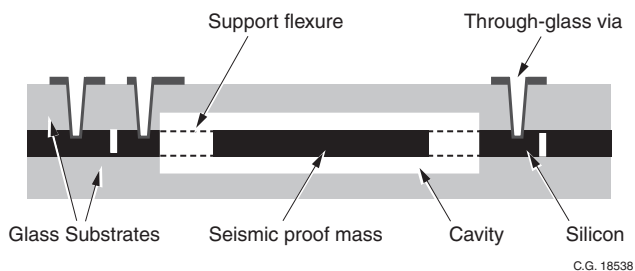

**Figure 11.3 Schematic Section of the Silicon On Glass Accelerometer MEMS Wafer Sub-Assembly**

### Pedestal

The hub of the MEMS gyro ring is supported above the ASIC on a 1mm diameter cylindrical silicon pedestal, which is bonded to the ring and ASIC using an epoxy resin.

### ASIC

The ASIC is a 5.52mm x 3.33mm device fabricated using 0.35µm CMOS process. ASIC and MEMS are physically separate and are connected electrically by using gold bond wires and thus the ASIC has no MEMS-to-ASIC internal tracking, meaning there is reduced noise pick-up and excellent EMC performance. Gold bond wires also connect the ASIC to the internal bond pads on the Package Base.

### Package Base and Lid

The LCC ceramic Package Base is a multi-layer aluminium oxide construction with internal bond wire pads connected through the Package Base via integral multi-level tungsten interconnects to a series of external solder pads. Similar integral interconnects in the ceramic layers connect the Lid to Vss, thus the sensitive elements are inside a Faraday shield for excellent EMC. Internal and external pads are electroplated gold on electroplated nickel.

The Package Base incorporates a seal ring on the upper layer onto which a Kovar® metal Lid is seam welded using a rolling resistance electrode, thus creating a totally hermetic seal. Unlike other MEMS Inertial Sensor packages available on the market, the DMU11 Combi Sensor has a specially developed seam weld process which eliminates the potential for internal weld spatter. Inferior designs can cause dislodged weld spatter which affects gyro reliability due to interference with the vibratory MEMS element, especially where the MEMS structure has small gaps, unlike Combi-Sensor with its large gaps as described above.

### Theory of Operation (Gyro)

The rate sensor is a solid-state device and thus has no moving parts other than the deflection of the ring itself. It detects the magnitude and direction of angular velocity by using the 'coriolis force' effect. As the gyro is rotated coriolis forces acting on the silicon ring cause radial movement at the ring perimeter.

There are eight actuators/transducers distributed evenly around the perimeter of the silicon MEMS ring. Located about its primary axes (0° and 90°) are a single pair of 'primary drive' actuators and a single pair of 'primary pick-off' transducers. Located about its secondary axes (45° and 135°) are two pairs of 'secondary pick-off' transducers.

The 'primary drive' actuators and 'primary pick-off' transducers act together in a closed-loop system to excite and control the ring primary operating vibration amplitude and frequency (22kHz). Secondary 'pick-off' transducers detect radial movement at the secondary axes, the magnitude of which is proportional to the angular speed of rotation and from which the gyro derives angular rate.

The transducers produce a double sideband, suppressed carrier signal, which is demodulated back to a baseband. This gives the user complete flexibility over in system performance, and makes the transduction completely independent of DC or low frequency parametric conditions of the electronics.

### Referring to Figures 11.4(a) to 11.4(d)

Figure 11.4(a) shows the structure of the silicon MEMS ring. Figure 11.4(b) shows the ring diagrammatically, the spokes, actuators and transducers removed for clarity, indicating the Primary Drive actuators (single pair), Primary Pick-Off transducers (single pair) and Secondary Pick-Off transducers (two pairs). In Figure 11.4(b) the annular ring is circular and is representative of the gyro when unpowered.

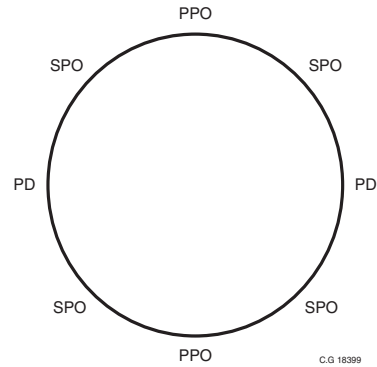

Figure 11.4(b)

When powered-up the ring is excited along its primary axes using the Primary Drive actuators and Primary Pick-Off transducers acting in a closed-loop control system within the ASIC. The circular ring is deformed into a 'Cos2θ' mode which is elliptical in form and has a natural frequency of 22kHz. This is depicted in Figure 11.4(c). In Figure 11.4(c) the gyro is powered-up but still not rotating. At the four Secondary Pick-Off nodes located at 45° to the primary axes on the ring perimeter there is effectively no radial motion.

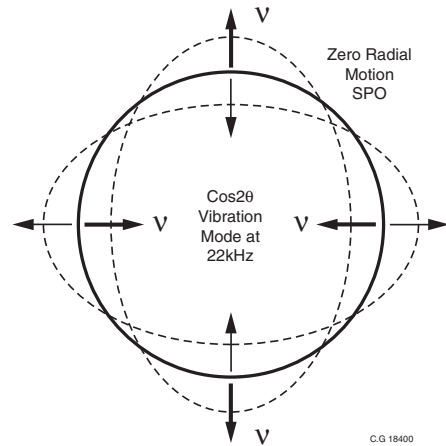

Figure 11.4(c)

If the gyro is now subjected to applied angular rate, as indicated in Figure 11.4(d), then this causes the ring to be subjected to coriolis forces acting at a tangent to the ring perimeter on the primary axes. These forces in turn deform the ring causing radial motion at the Secondary Pick-Off transducers. It is the motion detected at the Secondary Pick-off transducers which is proportional to the applied angular rate. The signal is demodulated with respect to the primary motion, which results in a low frequency component which is proportional to angular rate. All of the gyro control circuitry is hosted in the ASIC. A block diagram of the ASIC functions is given in Figure 1.1 in Section 1.

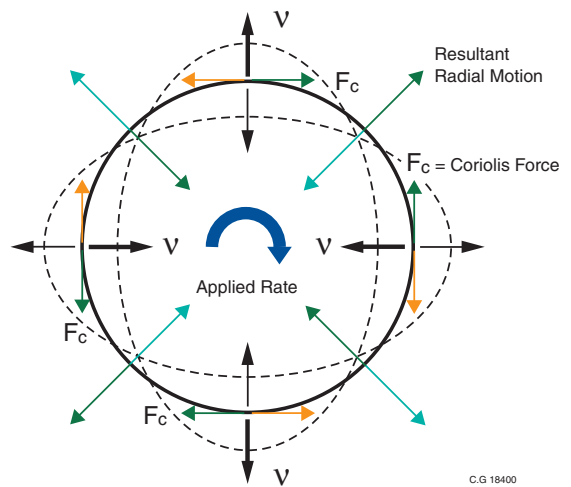

Figure 11.4(d)

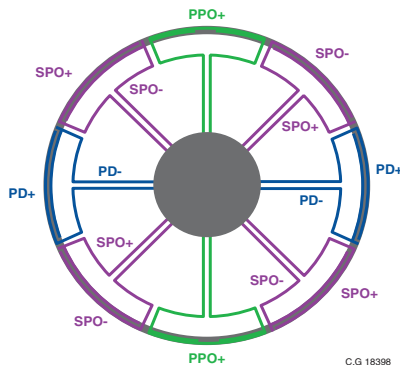

Figure 11.4(a)

## Theory of Operation (Accelerometer)

The accelerometer contains a seismic ‘proof mass’ with multiple fingers suspended via a ‘spring’, from a fixed supporting structure. The supporting structure is anodically bonded to the top and bottom glass substrates and thereby fixed to the sensor package base.

When the accelerometer is subjected to a linear acceleration along its sensitive axis, the proof mass tends to resist motion due to its own inertia, therefore the mass and it’s fingers becomes displaced with respect to the interdigitated fixed electrode fingers (which are also fixed to glass substrates). Air between the fingers provides a damping effect. This displacement induces a differential capacitance between the moving and fixed silicon fingers which is proportional to the applied acceleration.

Capacitor plate groups are electrically connected in pairs at the top and bottom of the proof mass. In-phase and anti-phase waveforms are applied by the ASIC separately to the ‘left’ and ‘right’ finger groups. The demodulated waveforms provide a signal output proportional to linear acceleration.

Figures 11.5(a) and 11.5(b) provide schematics of the accelerometer structure and control loop respectively.

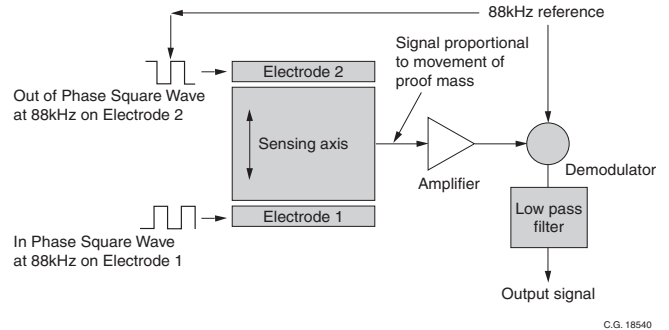

**Figure 11.5(b) Schematic of Accelerometer Control Loop**

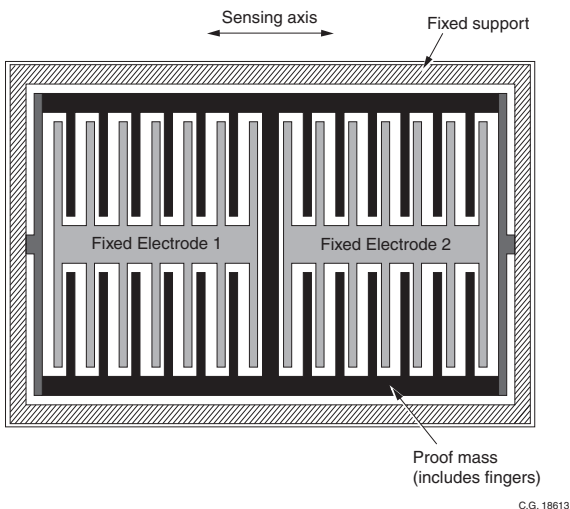

**Figure 11.5(a) Schematic of Accelerometer Structure**



# DMU11 Technical Datasheet

Low Cost 6-DOF Precision  
MEMS Inertial Measurement Unit



[www.siliconsensing.com](http://www.siliconsensing.com)

## Notes

# DMU11

Technical Datasheet

Low Cost 6 DOF Precision  
MEMS Inertial Measurement Unit



www.siliconsensing.com

## Notes

Silicon Sensing Systems Limited  
Cliffa Road Southway  
Plymouth Devon  
PL6 6DE United Kingdom

T: +44 (0)1752 723330  
F: +44 (0)1752 723331  
E: sales@siliconsensing.com  
W: siliconsensing.com

Silicon Sensing Systems Japan Limited  
1-10 Fuso-Cho  
Amagasaki  
Hyogo 6600891 Japan

T: +81 (0)6 6489 5868  
F: +81 (0)6 6489 5919  
E: sssj@spp.co.jp  
W: siliconsensing.com

Specification subject to change without notice.

© Copyright 2019  
Silicon Sensing Systems Limited  
All rights reserved.

Printed in England 03/2019  
Date 05/03/2019

DMU11-00-0100-132 Rev 5  
DCR No. 710015914