

## Falcon K1 LiDAR

Falcon K1 is an industry-leading automotive-grade LiDAR developed by Seyond through forward engineering. It can detect objects as far as 500 meters, and dark objects with 10% reflectivity up to 250 meters. Falcon can maximize point density in region of interest (ROI) which is adjustable to focus where it matters most to better track objects on the road. High performance LiDAR with strong environmental adaptability like Falcon is key to safe autonomy and smart transportation.



## Features

- 500m ultra-long detection range, image-grade ultra-high resolution
- Flexible and adjustable ROI
- 1550nm laser wavelength enables better eye-safety
- Greater environmental adaptability and longer product life
- Mass production of automotive-grade robust products is ready

## Specifications

OPTICAL PERFORMANCE	
Range (Maximum)	500 m
Range (Minimum)	1.5 m
Detection Range (10% Lambertian reflectivity @ 10 Hz)	250 m@100 klx sunlight, POD>90%
Detection Range Accuracy Note: "Accuracy is calculated based on the discrepancy between the average of 50 measurements on static target at a specific distance and the true distance"	±2cm
Detection Range Precision	Up to 2cm (1 standard deviation)
Detection Range Resolution	0.5 cm
Vertical Scanning Lines	1480 lines/sec
FOV in non-ROI (H×V)	120°×25°
FOV in ROI (H×V)	120°×9.6°
Angular Resolution in non-ROI (H×V)*	0.2°×0.24°
Angular Resolution in ROI (H×V)*	0.1°×0.15° (1 <sup>st</sup> 4.8°), 0.1°×0.1°(2 <sup>nd</sup> 4.8°)
Angular Accuracy	± 0.1°
Frame Rate*	10 FPS
False Positive Rate	<0.01% @ 100 klx sunlight
# of Returns	Up to 2 returns
LASER	

Laser Safety Class	Class 1 (IEC 60825-1:2014)
Laser Wavelength	1550 nm
Beam Divergence (Full Angle)	0.1°
<b>LIDAR OUTPUT</b>	
Data transmission	1000Base-T1 Ethernet (UDP,TCP/IP)
Points Per Second	1370000 Points/sec@1 return 2740000 Points/sec@2 return
Data Rate (Megabits Per Second)	11.69MB/S@1 return 17.45MB/S@2 return
Data Output	radius, azimuth, reflectivity, timestamp, frame ID, return mode, working mode, fault state, CRC verification, etc.
<b>CONTROL INTERFACE</b>	
Interface	TCP and HTTP APIs
Time Synchronization	<ul style="list-style-type: none"> <li>• IEEE1588 (PTP), accuracy: &lt;1μs error</li> <li>• IEEE 802.1as(gPTP) , accuracy: &lt;1μs error</li> <li>• NTP</li> </ul>
<b>MECHANICAL/ELECTRICAL</b>	
Power Consumption	30W
Operating Voltage	9 to 32V DC
Standard Voltage	12V DC
Connector	Proprietary pluggable connector (Power + Automotive Ethernet + CAN)
Dimensions (H×W×D)	58.9mm×228mm×149.6mm
Weight	1.7 kg
Mounting	4×M4×18 screws, located in bushings
<b>OPERATIONAL</b>	
Operating Temperature	-40 °C to +85 °C
Storage Temperature	-40 °C to +105 °C
Ingress Protection	IP67(body) IP69K(window)
Shock	IEC 60068-2-27 (Pulse shape: Half-sine. Peak acceleration: 500m/s <sup>2</sup> . Duration of pulse: 6ms. Number of shocks per direction (±X, ±Y, ±Z): 10 shocks.)
Vibration	IEC 60068-2-64 r.m.s. acceleration value: 30.8 m/s <sup>2</sup> , 3 axes 8 hr duration each
Compliance	IEC60825-1 Class 1 eye-safe RoHS (EU) CE Mark(EN IEC 61000-3-2:2019+A1:2021, EN 61000-3) 
<b>ACCESSORIES</b>	
Optional Wire Harness	5m cable (power & Ethernet)
Optional Converter	Metadapter
Optional Mount	Metal bracket
<b>SOFTWARE</b>	
Available Drivers	ROS/ROS2

## Dimensions (Unit: mm)

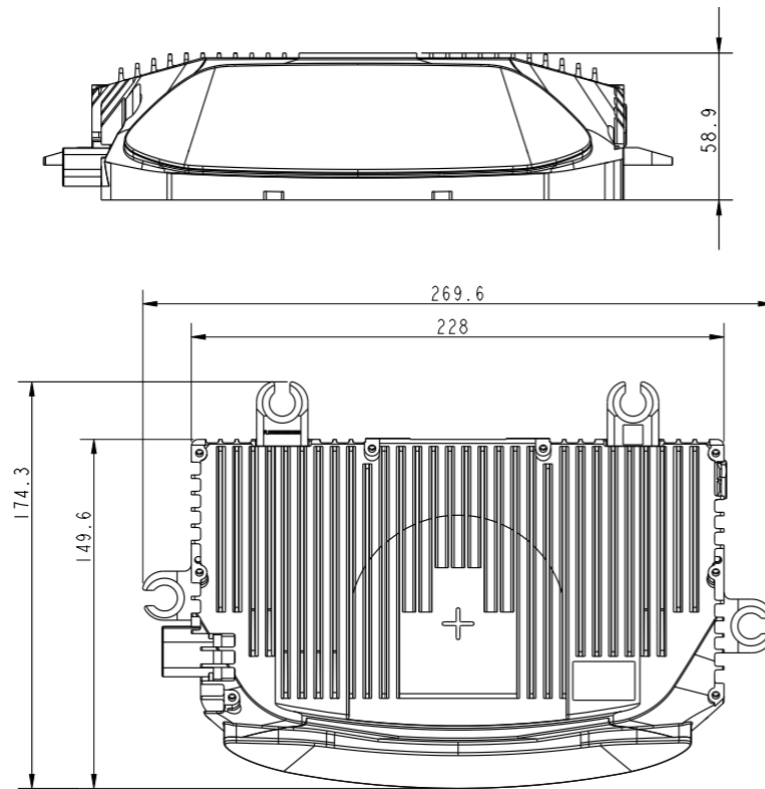

\*Specifications are subject to change without notice and based on engineering targets. Specs are not guaranteed to have passed full validation at the time of publication.