

TW605 Family of Low Noise Amplifiers for Choke Ring Antennas

Overview

The TW605 family of low noise amplifiers (LNA) are optimized for all GNSS bands utilized by the GPS, GLONASS, Galileo, and BeiDou satellite systems. This LNA is designed for integration into existing choke ring antennas thereby upgrading them to receive the entire GNSS band.

The TW605 provides 50 dB of gain. Custom pre-filtering provides suppression of outof-band interfering signals such as cellular LTE, Ligado, and Iridium satellite communications, while maintaining a low noise figure, high third order intercept point and small group delay.

Meeting the requirements of high performance GNSS receivers, the current consumption is less than 50mA with a 5 VDC supply.

The amplifier housing is compatible with choke ring antennas manufactured by Trimble, Allen Osborne, Ashtech, and Leica (504).



Features

- Available with 50 dB gain
- Low Current / low voltage
- Very low noise
- Wide input voltage 3 to 16 Volts
- Powered via antenna coax from receiver
- 50 Ohm port impedance
- RoHS and REACH compliant

Benefits

- Upgrades choke ring antennas to receive the full GNSS band or subset thereof
- High gain enables extended cable runs
- Easy to install

TW605 Family of Low Noise Amplifiers for Choke Ring Antennas

Specifications

Vcc =5V, over full bandwidth, T=25 °C

	TW60x
Signals	L1 L2 L5 G1 G2 G3 E1 E5a E5b E6 B1 B2 B3
L-Band (1525-1559MHz)	Yes
Pass band ripple (dB-max)	1164 - 1300: 2.0 1525 - 1610: 1.0
Out of Band Rejection (dB-min)	< 800 MHz: > 65 < 900 MHz: 25 <1430 MHz: 29 > 1700 MHz: 45 > 1800 MHz: > 70
Group Delay Variation (ns-max)	1164 - 1300: 5 1525 - 1610: 5
Noise Figure (typ)	1164 - 1300: 2.5 1525 - 1610: 2.5

Electrical

- Impedance 50 Ohms
- Input VSWR 2:1 max input
- Output VSWR 1.5:1 max output
- Supply Range voltage 3 to 16 VDC Nominal, 12 VDC recommended operating max
- Supply Current 50 mA max

Drawings (all dimensions in mm)

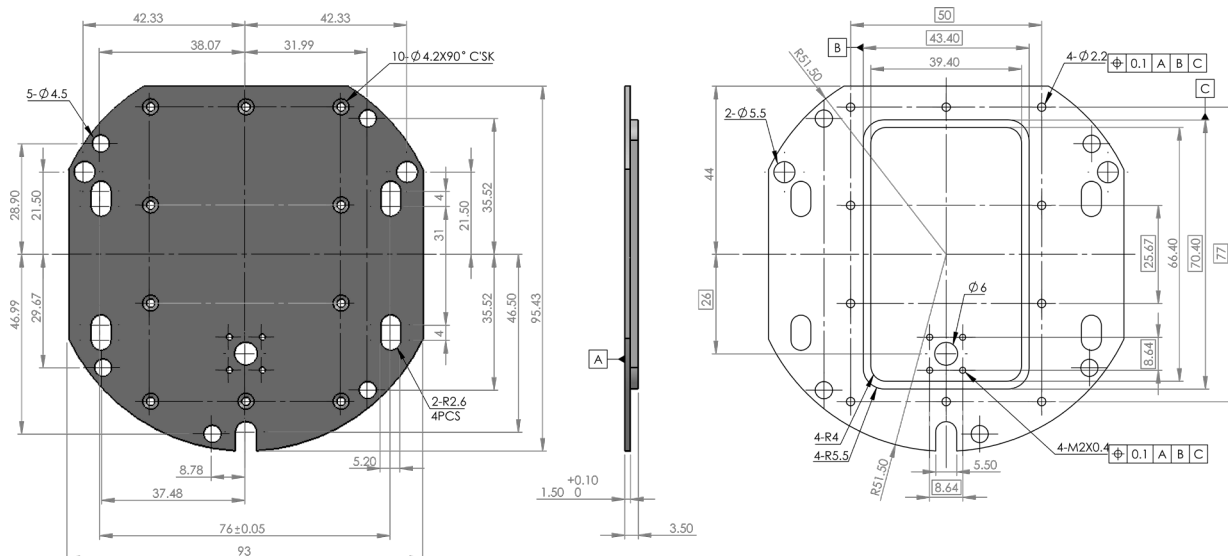

TW605 Family of Low Noise Amplifiers for Choke Ring Antennas

Mechanicals & Environmental

Mechanical Size (body dimensions only)	98.0 mm x 93.0 mm x 17.6 mm
Connectors	SMA Jack
Operating Temp. Range	-55 to +85 °C
Environmental	RoHS, REACH compliant
Warranty	One year – parts and labour

Ordering Information

TW605 – 50 dB gain Choke Ring Amp with SMA Jack (Full GNSS Spectrum + L-Band) 32-0605-00-yyy

Replace yyy with the make of choke ring as follows:

TRI = Trimble Choke Ring ASH = Ashtech LEI = Leica AOA = Allan Osborne and Associates



When precision matters.®

About Tallysman: With global headquarters and manufacturing in Ottawa, Canada, Tallysman is a leading manufacturer of high-precision antennas and components for Global Navigation Satellite System (GNSS) applications. Tallysman's mission is to support the needs of a new generation of positioning systems by delivering unprecedented antenna precision at competitive prices. Learn more at www.tallysman.com

© 2023 Tallysman Inc. All rights reserved. Tallysman, the "When Precision Matters" tag line and the Tallysman logo are trademarks or registered trademarks of Tallysman Inc. and/or its affiliates in Canada and certain other countries. All other trademarks mentioned in this document are the property of their respective owners. The information presented is subject to change without notice. Tallysman assumes no responsibility or any errors or omissions in this document. Tallysman Wireless Inc. hereby disclaims any or all warranties and liabilities of any kind.

Tallysman TW600 Family Datasheet v1.7 EN

Contact us:

info@tallysman.com

T: +1 613 591-3131

www.tallysman.com